



Logic 5.0 The Next Generation of Commercial Door Operators

Gearhead Trolley (GT) style commercial door operators employ lubricated gears and are optimal for heavy industrial, high-cycle applications. Suspended from the ceiling, the operators are used on sectional overhead doors with a standard lift. GT operators are directly attached to drive and control the door.

Connectivity

- **MyQ® Technology** enables you to securely monitor and control your facility operator and lights with your smartphone, tablet or computer for greater peace of mind.
- **Alerts** can be received as email or pop-up (push) notifications on a mobile device, ensuring the status of your commercial door.
- **MyQ Mobile App** is a free download with no annual activation fee.

Safety and Security

- **Security+ 2.0™** safeguards your facility – with every click, a new code is sent to the commercial door operator so the door opens only for you.

UL 325 requires all commercial door operators to be either constant pressure to close or be equipped with a primary external monitored entrapment protection device.

LiftMaster® is the leading brand of professionally installed commercial door operators and access control products for businesses worldwide. We are committed to quality products, innovative designs and comprehensive services which exceed our Customers' expectations.

MyQ Accessories:



Internet Gateway (828LM)

Enables owners of commercial door operators to connect their operators to the Internet to monitor, control and receive alerts regarding status of each door.



Door and Gate Monitor (829LM)

Enables monitoring and closing within a facility of up to four commercial doors.



Remote Light Control (825LM)

Operates a plug-in light using a commercial door operator remote control, or the LiftMaster Internet Gateway using your smartphone or computer.

Entrapment Protection Devices:



Monitored Dual-Sided Photo Eyes (CPS-OPEN4)

Provides primary entrapment protection on doors up to 45ft wide. NEMA 4X rated.



Monitored Optical Edge System (OES)

Thru-beam infrared optical sensors, premium rubber door edge that can be cut to length for exact fit.

Additional Accessories:



3-Button Remote Control (893MAX)

Provides Security+ 2.0™ Technology and compatible with multiple radio technologies. Includes open, close and stop functionality.



Mushroom Button Control Station (02-401M)

Provides single button to activate opening one or more commercial doors.



Red/Green Traffic Light (RGL24LY)

Indicates when a commercial door reaches the open position. Provides assurance of safe entering and exiting of the facility, reducing the potential for costly accidents. (TLS1CARD is recommended)

STANDARD FEATURES:

DUAL VOLTAGE CONNECTIONS

Increase flexibility by enabling the installer to select the required voltage, within phase, to meet job-site requirements.

Within phases, voltage is selectable at the time of installation with the placement of a connector.

- Single-Phase: 115V and 230V
- 3-Phase: 208V, 230V and 460V
- 575V is a discrete model without field-selectable voltage

EMERGENCY DISCONNECT

Disconnects operator from door for manual lifting in an emergency.

HEAVY-DUTY WORM GEAR-IN-OIL GEAR REDUCER

Delivers performance for heavy industrial, high-cycle applications.

CONTROL FUNCTION SELECTOR DIAL

Enables easy selection and programming of (7) wiring types, from constant pressure to close, to specialized Timer-to-Close functionality to meet end-user needs.

TIMER-TO-CLOSE

Conveniently and confidently closes the commercial door automatically after a predetermined amount of time has elapsed for added security and peace of mind.

CONTINUOUS-DUTY HIGH-STARTING TORQUE MOTOR

Performs in demanding industrial overhead door applications.

MOTOR REMOVABLE WITHOUT AFFECTING LIMIT SWITCH SETTINGS

Saves time and money for maintenance.

ADJUSTABLE FRICTION CLUTCH

Helps to protect door and operator from damage should the door meet an obstruction.

MID-STOP

Enables partial opening of door to a preprogrammed position for energy savings, time savings and convenience.

MAXIMUM RUN TIMER

Reverses or stops door if closing time exceeds expected time-frame to limit damage to door and operator.

DELAY-ON-REVERSE CIRCUIT

Prevents abrupt reversal of door, reducing wear on the door and operator system.

3-BUTTON CONTROL STATION WITH MAINTENANCE ALERT SYSTEM (MAS)

Provides open/close/stop functions and notification when routine maintenance is required.

SPECIFICATIONS:

SECURITY+ 2.0™ RADIO RECEIVER

Standard on-board with Logic 5.0 operators. Accepts up to (90) single-button or (30) 3-Button remote controls plus up to (30) wireless keypads or an unlimited number of DIP switch remotes.

MOTOR

Continuous-duty high-starting torque motor with instant reverse and overload protection. Available in 1/2, 3/4, 1 and 1-1/2 HP; single- or three-phase. Capacitor start on single-phase.

WIRING TYPE

Operators are factory preset to C2 wiring, providing momentary contact to open and stop, with constant contact to close. Monitored entrapment protection, using approved photo sensors or sensing edges is optional, although recommended, when using C2, D1 or E2. All other wiring types, B2, T, TS and FSTS can be selected with the addition of an appropriately monitored entrapment protection device (LiftMaster® CPS-U photo eyes, LiftMaster OES monitored sensing edge, or a monitored sensing edge supported by the CPS-EI, as examples). Logic 5.0 operators can only accept UL-Approved LiftMaster monitored entrapment protection devices.

CONTROL CIRCUIT

5V DC NEC Class 2.

DRIVE REDUCTION

10:1 first-stage using heavy-duty gears running in oil bath; cast iron housing; #41 chain second stage; #41 output chain on trolley.

BEARINGS

Sealed roller bearings in gear reducer. Flange-mount industrial ball bearings on drive shaft.

BRAKE

Standard on all GT operators.

CONSTRUCTION

NEMA 1 type electrical box, heavy-duty 11-gauge steel frame with durable powder coat finish, all reduction sprockets drilled and pinned to shafts.

#41 TROLLEY ROLLER CHAIN

Standard on GT Operators.

WARRANTY

Two Years.

TECHNICAL INFORMATION:

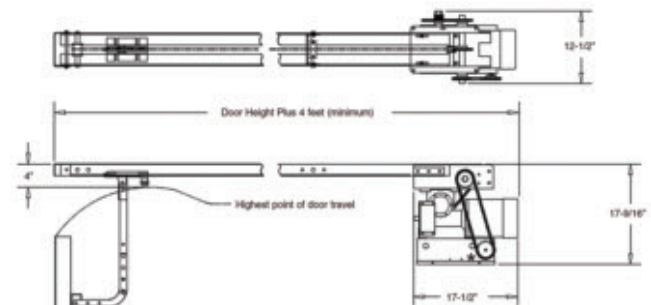

		MAXIMUM DOOR AREA (SQ. FT.)				
STANDARD SECTIONAL	—	24 ga. Steel	20 ga. Steel	16 ga. Steel	—	
	Fiberglass	Aluminum Doors	Wood Doors	—	—	
	—	—	24 ga. Steel Insulated	20 ga. Steel Insulated	16 ga. Steel Insulated	
HP	1/2	400	350	320	250	200
	3/4	560	500	450	325	250
	1	625	575	500	400	300
	1-1/2	—	625	550	475	380

NOTE: On steel insulated doors, a 24-gauge back panel is assumed. If a heavier back panel is supplied, use the next higher HP rating. Recommended Duty Cycles: 25 per hour, in excess of 90 per day.